

2

1

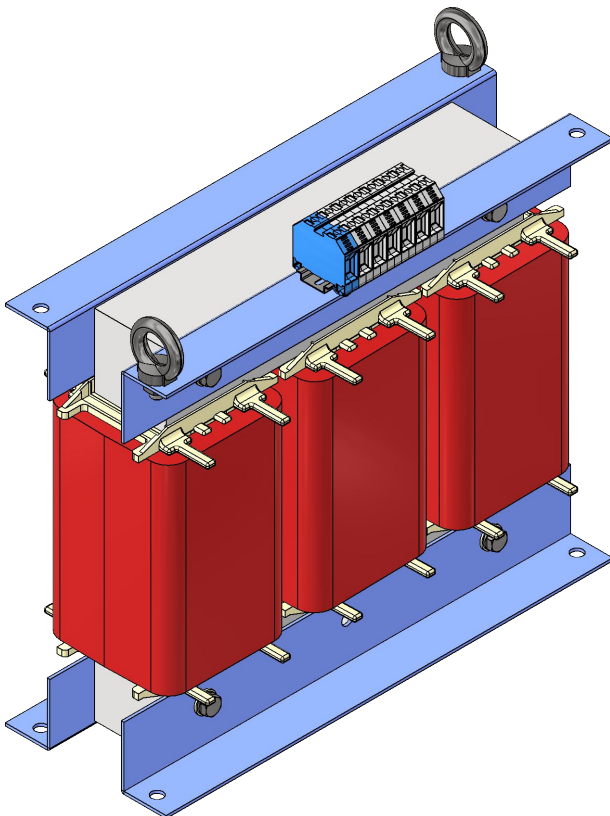
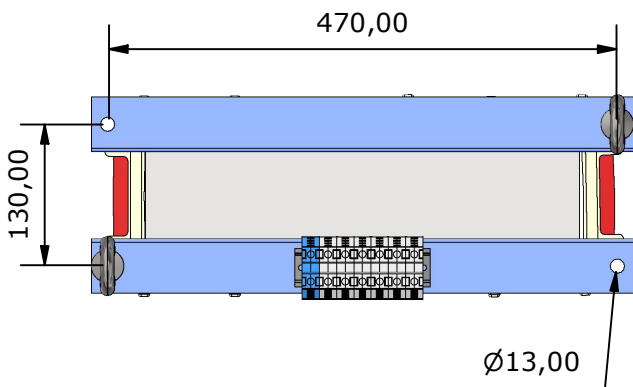
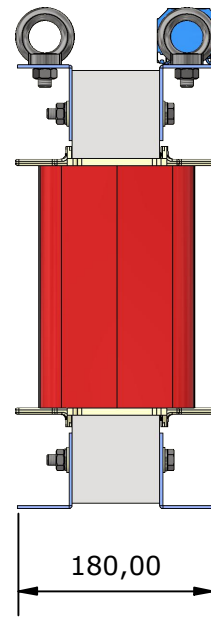
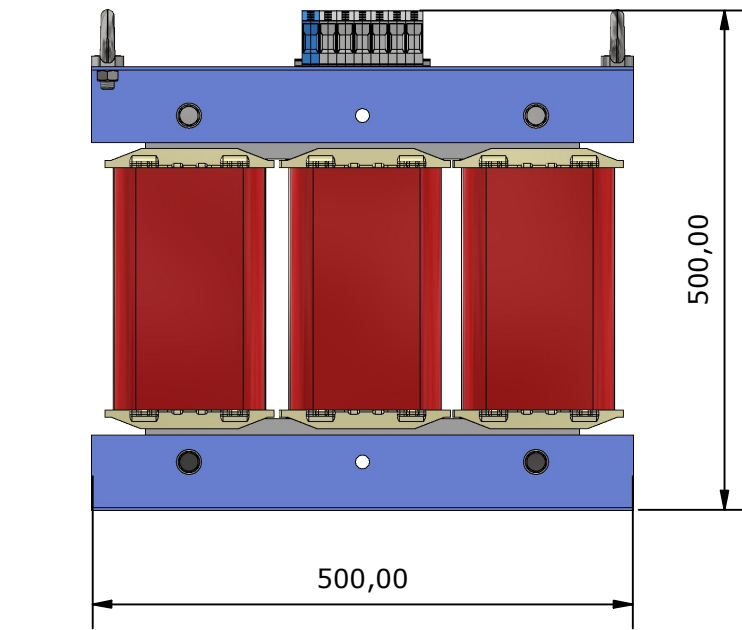

TECHNICAL DATA

According Standard	EN-61.558-2-13
Rated Power	60 KVA
Primary Voltage	400/690V + N
Secondary Voltage	400/690V + N
Frequency	50/60 Hz
Protection Grade	IP-00
Isolement Level	F
ED:	100%
ta	40°C
Class	I
Strength Dielectric test between live parts	-
Strength Dielectric test between live parts and mass	2.750V
Data Plate	Yes
Electrostatic screen	Non
Wound wires	Aluminum wire G-2 class H
Magnetic Core	Non oriented grain, cold lamination. M 330-50A EN10106
Bobbin	PA6 + Glass Fiber (30%)
Type Refrigeration	Dry
Connection	YN
Terminal block	CONTA CLIP 35mm
Weight	102 Kg.

Drew by:

Miguel A. Hdez. - 28/03/2023

Approved by:

Victor Gallego - 28/03/2023

THREE-PHASE AUTOTRANSFORMER

Units:
mm.

XMN02360960

Page 1 de 1
Rev: 01
Rev date.: 28/03/2023

MANUMAG SL - C/Antonio Barriendos s/n, Pol. Ind. Las Norias
50450-MUEL, SPAIN - VAT ESB50040146
Tel +34 976 140606 - Fax +34 976 140 607
comercial@manumag.com, export@manumag.com



2

1