

2

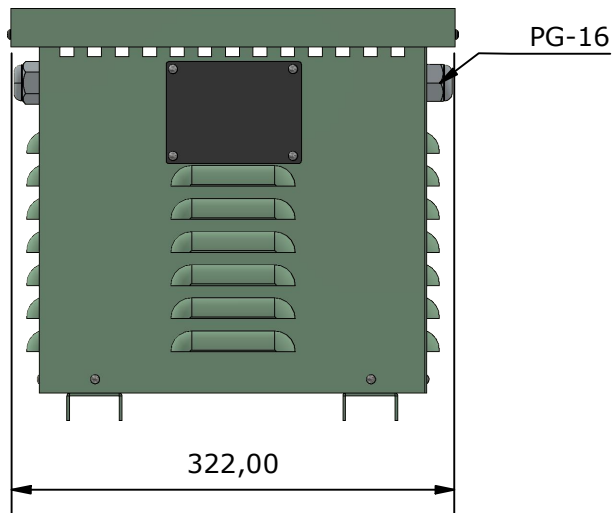

1

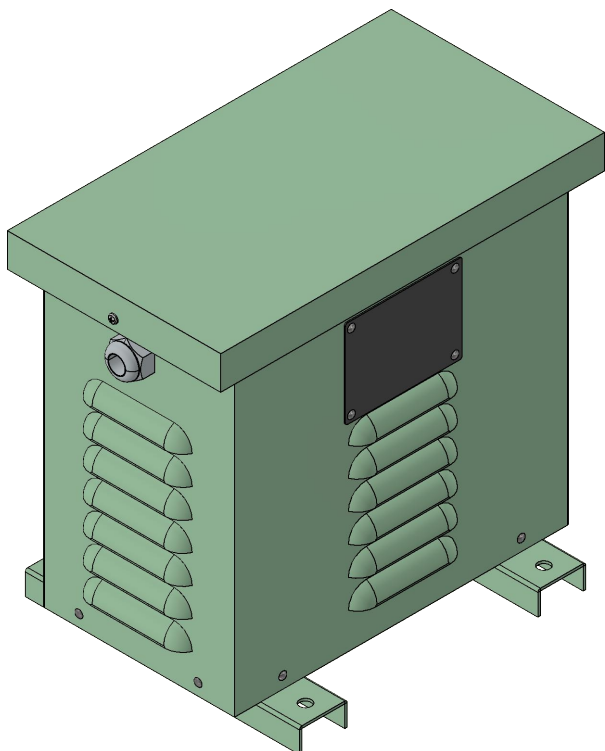
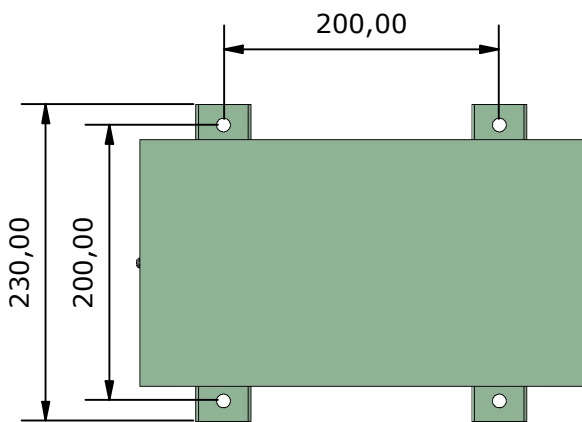
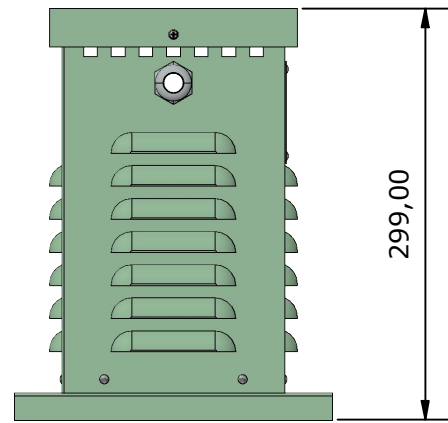

### TECHNICAL DATA

According Standard	EN-61.558-2-4
Rated Power	2 KVA
Primary Voltage	400V (III)
Secondary Voltage	230V (I)
Frequency	50/60 Hz
Protection Grade	IP-23
Isolement Level	F
ED:	100%
ta	40°C
Class	I
Strength Dielectric test between live parts	4.600V
Strength Dielectric test between live parts and mass	3.500V
Data Plate	Yes
Electrostatic screen	Non
Wound wires	Cooper wire G-2 class H
Magnetic Core	Non oriented grain, cold lamination. M 330-50A EN10106
Bobbin	PA6 + Glass Fiber (30%)
Type Refrigeration	Dry
Connection	V-v inv.
Terminal block	CONTA CLIP 6mm
Weight	18 Kg.

Drew by:

Miguel A. Hdez. - 08/05/2023

Approved by:

Victor Gallego - 08/05/2023

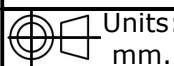
THREE PHASE-SINGLE PHASE ISOLATION  
TRANSFORMERUnits:  
mm.

YZV02205403

Page 1 de 1  
Rev: 01  
Rev date.: 08/05/2023MANUMAG SL - C/Antonio Barriendos s/n, Pol. Ind. Las Norias  
50450-MUEL, SPAIN - VAT ESB50040146  
Tel +34 976 140606 - Fax +34 976 140 607  
comercial@manumag.com, export@manumag.com

2

1