

2

1

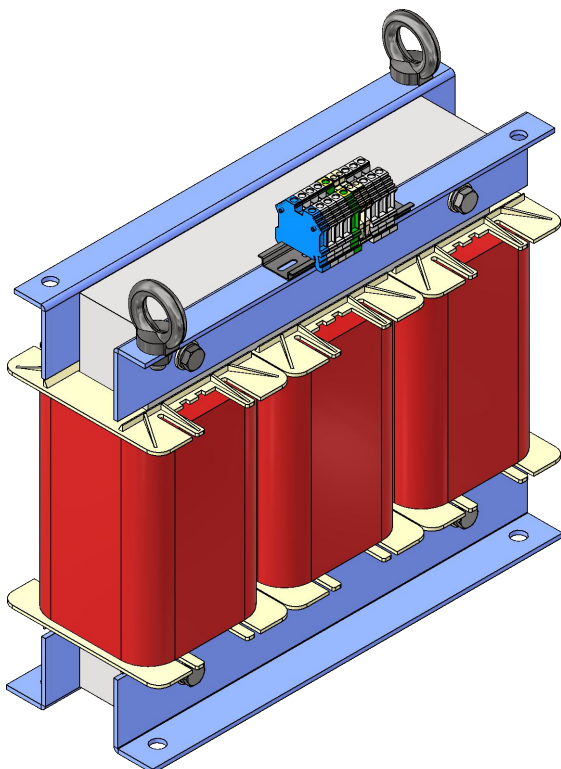
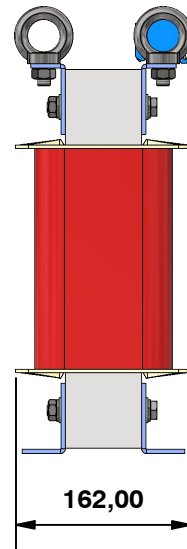
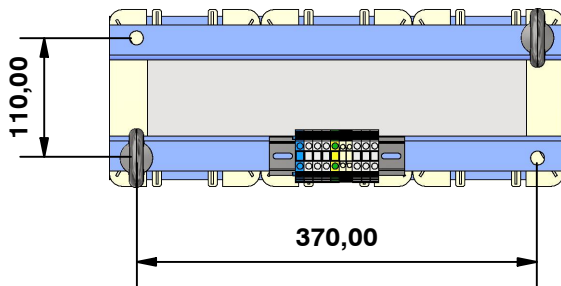
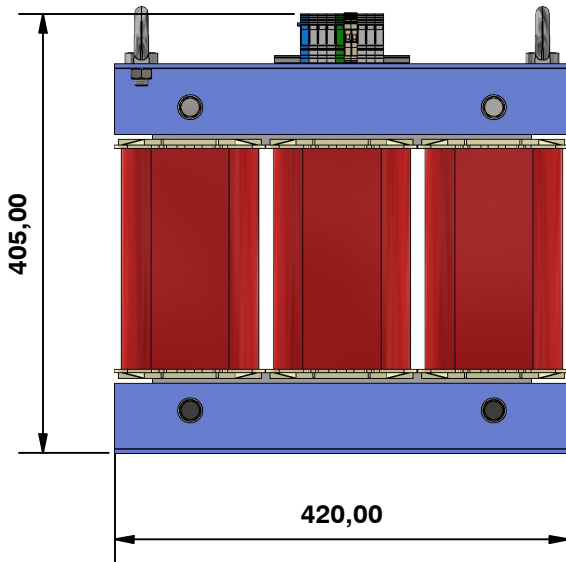

TECHNICAL DATA

According Standard	EN-61.558-2-15
Rated Power	7500 VA
Primary Voltage	400V+N
Secondary Voltage	230V
Frequency	50/60 Hz
Protection Grade	IP-00
Isolement Level	F
ED:	100%
ta	40°C
Ucc	8%
Protection temperature	NC 130°C
Strength Dielectric test between live parts	4.500V
Strength Dielectric test between live parts and mass	4.500V
Data Plate	Yes
Electrostatic screen	Yes
Wound wires	Cooper wire G-2 class H
Magnetic Core	Non oriented grain, cold lamination. M 330-50A EN10106
Bobbin	PA6 + Glass Fiber (30%)
Type Refrigeration	Dry
Connection	YNd
Terminal block	CONTA CLIP 10mm (PRI) CONTA CLIP 10mm (SEC)
Weight	81 Kg.

Drew by:

Miguel A. Hdez. - 02/02/2024

Approved by:

Victor Gallego - 02/02/2024

III-PHASE TRANSFORMER FOR MEDICAL LOCATIONS

**Units:
mm.**
YD802755440

 Page 1 de 1
 Rev: 01
 Rev date.: 02/02/2024

 MANUMAG SL - C/Antonio Barriendos s/n, Pol. Ind. Las Norias
 50450-MUEL, SPAIN - VAT ESB50040146
 Tel +34 976 140606 - Fax +34 976 140 607
 comercial@manumag.com, export@manumag.com

2

1